

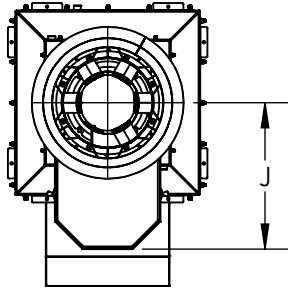

DATE: TAG:
 JOB:
 PROJECT:
 COMPANY:
 SALES PERSON:

IPLUME WITH 1X1 PLENUM
 BELT DRIVE, BOTTOM INLET



A = OVERALL SYSTEM HEIGHT (WITHOUT CURB)
 B = WIDTH OF PLENUM (INSIDE)
 D = OVERALL WIDTH OF THE SYSTEM
 E = HEIGHT OF PLENUM
 F = HEIGHT OF FAN
 G = DIA. OF NOZZLE
 H = DIA. OF WINDBAND COLLAR
 J = MAX. WEATHER COVER

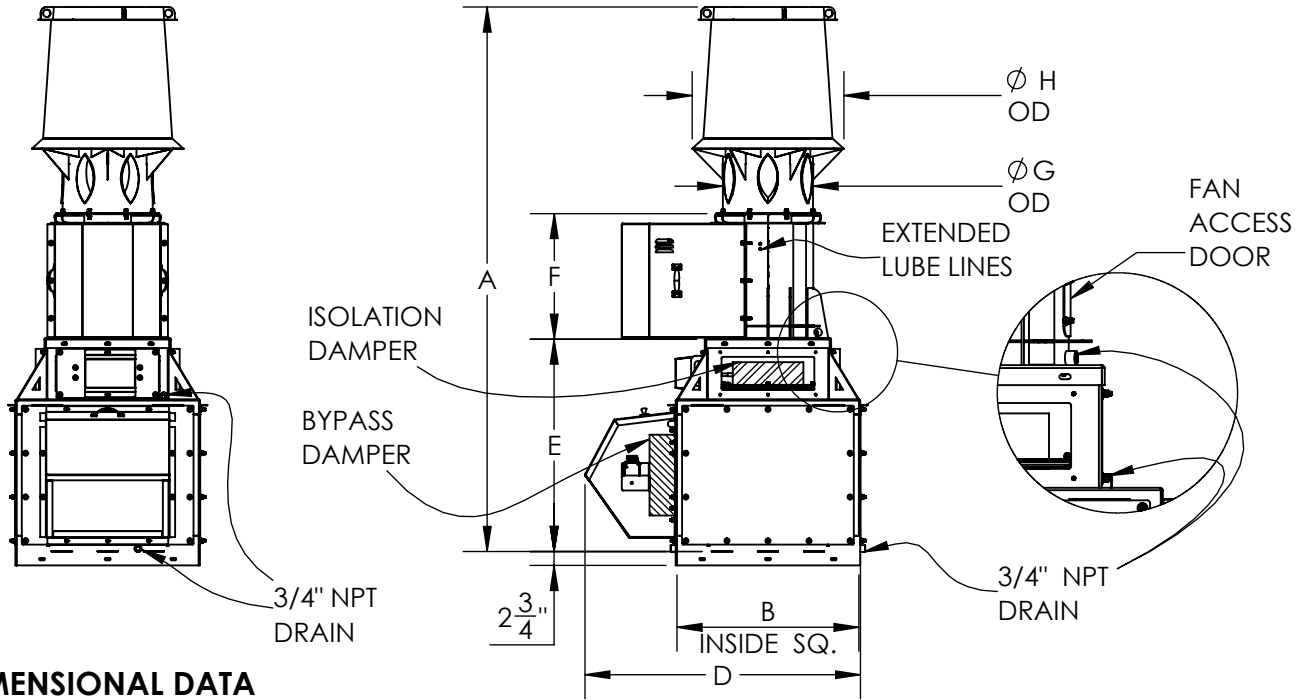

DIMENSIONAL DATA

Size	A	B	D	E	F	G	H	J	MAX MTR FRAME SIZE	LESS MOTOR/ DRIVE WEIGHT (LBS.)
122	107 3/4	36 5/16	54 1/2	42	24 7/8	17 7/8	30 1/16	28 15/16	184T	1074
135	114 3/4	39 5/16	57 1/2	42	27 9/16	19 3/4	33 1/8	29 3/4	215T	1186
150	122 11/16	45 5/16	63 1/2	42	30 5/8	21 15/16	36 13/16	33 7/8	256T	1388
165	123 5/8	46 5/16	64 1/2	42	33 11/16	23 7/16	40 5/8	34 7/16	256T	1474
182	138 7/16	53 5/16	73 5/8	48 1/16	37 3/16	25 13/16	44 15/16	35 3/8	256T	2128
200	146 13/16	57 5/16	77 5/8	48 1/16	40 15/16	28 3/8	49 3/16	36 5/8	256T	2305
222	157 15/16	61 5/16	81 5/8	48 1/16	45 7/16	31 7/16	54 3/4	40	286T	2614
245	155 15/16	62 5/16	82 5/8	50 3/4	50 3/16	34 11/16	53 9/16	41 9/16	286T	2738
270	163 15/16	65 5/16	85 5/8	48 1/16	55 5/16	38 3/16	59 1/16	45 1/2	326T	2937
300	182 7/8	71 5/16	93 3/4	54 1/16	61 1/2	42 7/16	65 9/16	49 7/16	365T	3471
330	196	78 1/4	100 3/4	54	67 3/4	46 5/8	72 1/8	51 9/16	365T	3931
365	193 1/2	81 1/4	103 13/16	60	74 15/16	51 5/8	67 3/8	56 1/2	405T	4601
402	206 15/16	86 1/4	108 13/16	60	82 9/16	56 3/4	74 5/16	59 1/8	405T	5139
445	246 15/16	92 1/4	123 1/4	84	91 7/16	62 3/4	82 1/8	65 3/8	444T	6331

ALL DIMENSIONS ARE IN INCHES

REVISION:

FORM:

REPLACES: